

TF03 analog signal version is an industrial-grade long-range LiDAR. Its maximum detection range can reach 100m. With integrated compensating algorithm for outdoor glare and other interference, TF03 can work under strong light environment and rain, fog and snow conditions¹. Multiple built-in operating modes let the customer to change its working parameters and configuration to meet different applications.



Main product features

- High frame rate
- IP67 protection
- Small size

Main application scenarios

- Vehicle collision avoidance and safety warning
- Traffic flow statistics
- Camera trigger

SPECIFICATIONS

Parameters		Typical Value
Product performance	Operating range (Indoor)	0.1...180m@90% reflectivity 0.1...70m@10% reflectivity
	Operating range (Outdoor @ 100Klux)	0.1...110m@90% reflectivity&100Klux 0.1...50m@10% reflectivity&100Klux
	Detecting Accuracy	±10cm (within 10m), 1% (10m and further) ²
	Current Accuracy	0.1mA
	Distance resolution	1cm
	Frame rate	1...1000Hz adjustable (default 100Hz)
	Repeatability	1σ <3cm
	Ambient light immunity	100Klux
	Operation temperature	-25...60°C
	Enclosure rating	IP67
Optical parameters	Light source	LD
	Central wavelength	905nm

¹ Rain, snow and fog conditions generally refer to moderate rain, snow and below. Moderate rainfall < 25mm/24h or < 7.9mm/h

² The detection range is measured at temperature of 25°C. Accuracy and repeatability are measured with white board (90% reflectivity).

	Photobiological safety	Class1 (EN60825)
	FOV	0.5°
Electrical parameters	Supply voltage	5...24V DC
	Average current	≤150mA @ 5V, ≤80mA @ 12V, ≤50mA @ 24V
	Power consumption	≤1W
	Communication interface	Analog Signal (Current, 4...20mA) & UART ³
Others	Dimension	44mm*43mm*32mm(L*W*H)
	Enclosure material	Aluminum alloy
	Storage temperature	-40...85°C
	Weight	92g±3g
	Cable length	70cm

DIMENSIONS

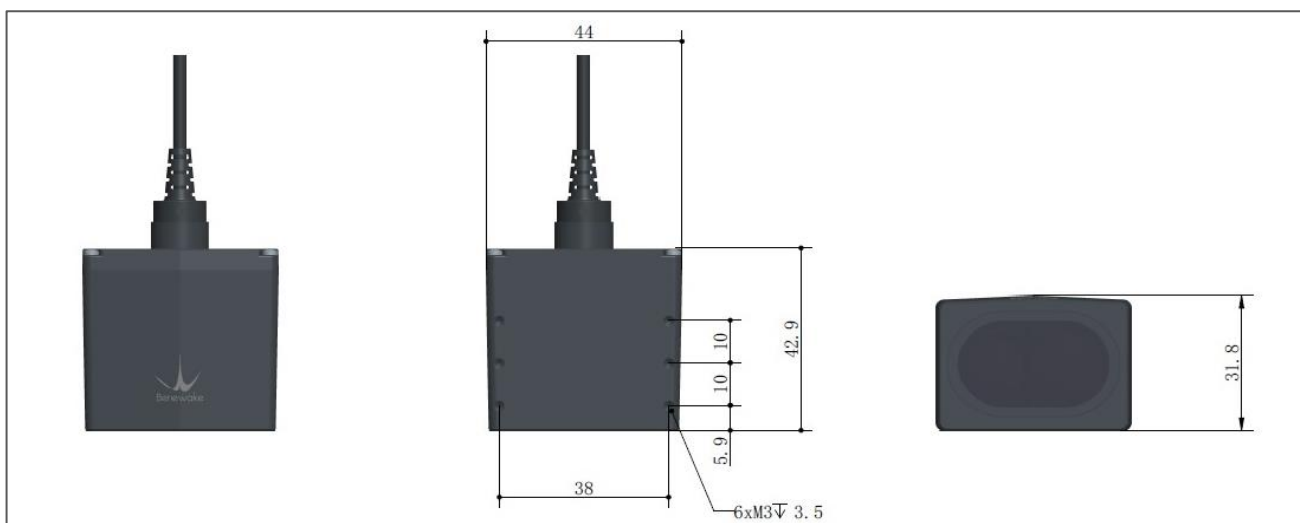

Figure 1 TF03-ANALOGVERSION dimensions (Left 1: top view; Left 2: upward view; Left 3: front view) Unit: mm

CONFIGURABLE PARAMETERS

Table 1 Configurable parameters example

Configurable parameters	Description	Default setting
Frame rate	Output frame rate could be configured by related command, range 1...1000Hz	100Hz
Baud rate	Serial port baud rate could be customized	/

Note: for more configurable parameters and instructions, please refer to the user manual.

³ The UART interface can only be used to config the LiDAR. It cannot transmit detection data.

■ WIRING

The connector of TF03 is Molex 1.25 W/B SD-51021-0700.

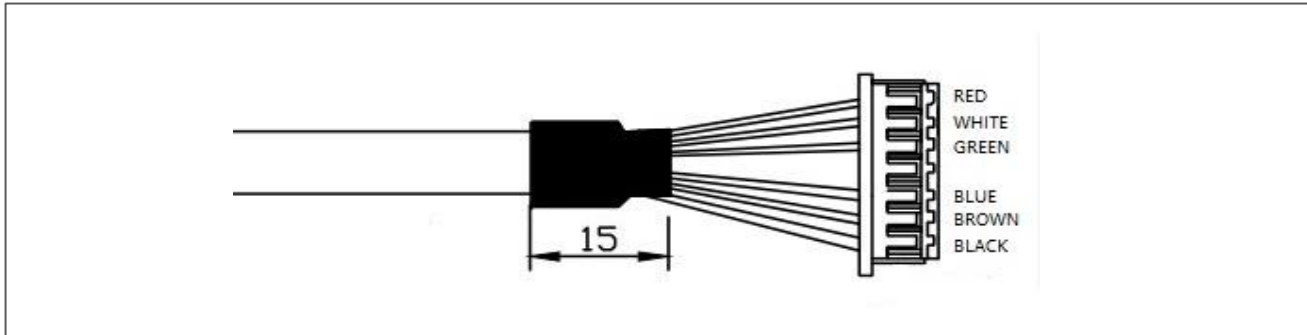

Figure 2 Wiring of new version TF03-ANALOGVERSION

Below is new version TF03's pin definition and function description.

No.	Color	Description	
		PIN definition	Function
1	Red	VCC	Power supply
2	White	/	/
3	Green	Analog Signals (Current)	4...20mA
4	/	/	/
5	Blue	UART_RX	UART receive(debug)
6	Brown	UART_TX	UART transport(debug)
7	Black	GND	Ground

■ CERTIFICATIONS



Benewake (Beijing) Co., Ltd

Address: Room 3030, Building ZiZhuChuangXin, No.6 Chuangye Road, Haidian District, Beijing, PRC

Phone: +86 010 5745 6983

Email: bw@benewake.com

Technical support: support@benewake.com